



The Caipy ChannelServer 4.3 enables Caipy's advertisement detection for live TV and on-demand video. Each ChannelServer takes input of up to 20 TV channels and transcodes to Caipy's proprietary CAI format for Caipy's cloud-based content discovery.



## Real-time Advertisement Detection

**Business intelligence** of TV advertisement

**Additional revenue** with time-shift Ad replacement

**Automated** Replay TV production

Caipy ChannelServer turns live audio/video feeds into recognizable and comparable content. It prepares TV feeds for content detection in real-time, and uses a very high precision for perfect results.

Advertisement discovery, detection, and replacement, now become reality where they have not been possible before.

The Caipy ChannelServer is deployed quickly, as it does not require altering the existing live TV data path.

*Unprecedented accuracy.*

*Detects sponsorships and ads as short as 3 seconds.*

*Frame-accurate and real-time*

## Interactivity

The Caipy ChannelServer keeps precise timing information in sync with the original TV signal. It enables interactivity via remote control or second screen applications, such as mobiles or tablets. This opens up a vast array of advanced TV applications, such as:

- **Interactive TV advertisement:** Actionable TV ads as soon as they appear on the screen.
- **SharpStart:** Correct the EPG and playback right where the content starts.
- **Differentiated TV Service:** with Ads, or Ads free - for different monthly fees.

## Rights Validation

The Caipy ChannelServer enables sports rights validation. Content owners can track live copies, repeats and partial repeats of live sports contents from the very first second the original content is on air. Deployed in parallel, the Caipy ChannelServer avoids the operational burden of watermarking.



## Fully Redundant Setup

Caipy ChannelServer is setup to receive from IRDs or encoders in MPEG.TS over IP Multicast and supports RTP or plain UDP protocols. It provides the ability to choose a program from a MPTS or filter via the supported source-specific multicast (SSM). For Internet-only sources HLS is supported as input.

Each ChannelServer enables two redundant unicast outputs towards Caipy SyncServers for each input TV channel and one common IP Multicast output locally.

Caipy ChannelServers are conceived for an operator-class redundant setup of 24/7 availability. Real-time fail-over is available in 1+1 redundancy. N+1 redundancy is available as of 40 channels.

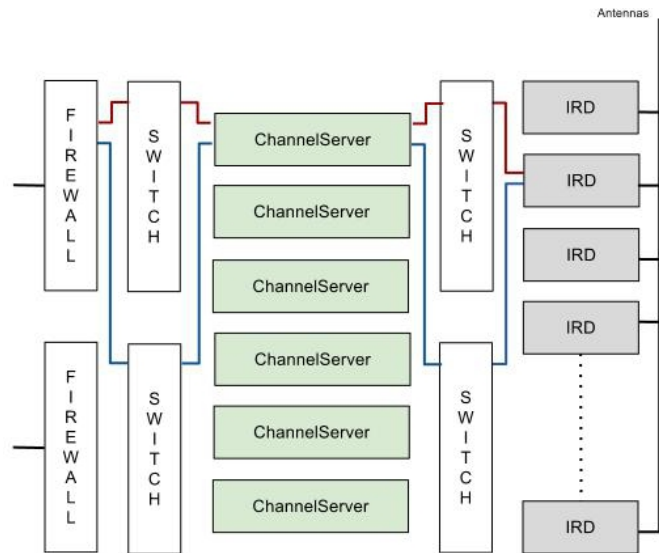

## System Hardware Requirements

Caipy ChannelServer is provided as a virtual machine (.ova) for 20 channels and takes full benefit of multi-core processors – the required hardware:

<b>Processing</b>	<b>Min. Intel Xeon 2.2 GHz, 10 core, 64 Bit</b>
<b>Memory</b>	<b>Min. 20 GB RAM</b>
<b>Internal Storage</b>	<b>2 x Min. 300GB 15k HDD in Raid 1</b>
<b>Input NIC (IP Multicast – IGMP v2 or v3 )</b>	<b>2 x Min. 1 Gbit/s Ethernet NIC</b>
<b>Output NIC</b>	<b>2 x Min. 1 Gbit/s Ethernet NIC</b>
<b>Management</b>	<b>Min. 100 Mbit/s Ethernet NIC</b>
<b>Power Supply</b>	<b>Redundant</b>
<b>Max. expected power consumption</b>	<b>350W</b>

## Related Caipy Products

Caipy SyncServer